

Background

The Belgian design for the disposal of the vitrified High-Level radioactive Waste considers the host-rock as the main barrier for the long term isolation in the normal evolution scenario. The effect of a large scale thermal load on the behaviour of Boom Clay is one important remaining issue in the feasibility study of the disposal. Indeed, the impact of the thermal load generated by the waste is particularly important since it will significantly affect the temperature and the stress profiles on the whole thickness of Boom Clay in the short term after the disposal. Therefore the early transient THM perturbation can be considered as the most severe impact that the repository system will undergo on a large spatial scale and in a relatively short period of time.

Objectives

The PRACLAY experiments are managed by ESV EURIDICE GIE (European Underground Research Infrastructure for Disposal of Nuclear Waste in Clay Environment). The main objective of the PRACLAY experiments is to verify that Boom Clay is suitable, in terms of performance of the disposal system, to undergo the thermal load induced by the vitrified waste. The test will focus on the study of the combined effect of the EDZ (Excavation Damaged Zone) and the thermal impact at repository scale. The influence of the temperature increase on the EDZ evolution as well as the possible additional damage created by the thermal load will be studied. The impact of the THMC (Thermo-Hydro-Mechanical and Chemical) response on the transport properties of the Boom Clay will also be assessed. A long term (more than 10 years) large scale heater test would be representative of the most penalizing conditions that could be encountered in the real disposal. The results of the test will constitute an important input for the SFC (Safety and Feasibility Case)-1, 2003 and 2, 2020.

Principal results

The design of the PRACLAY experiments is now fixed based on numerical simulations. The design phase included the definition of the geometry, the boundary conditions and the instrumentation programme. We developed the PRACLAY in-situ experiments to be design-independent to overcome possible future changes in the reference disposal design. The PRACLAY experiments will be performed within "The PRACLAY Gallery", which will be 45 m long with an internal diameter about 2 m, lined with concrete segments and perpendicular to the connecting gallery. The heater length will be about 30 m. The PRACLAY in-situ experiments regroup a set of three tests, as you can see on the picture:

- The gallery and crossing test
- The heater test
- The plug test

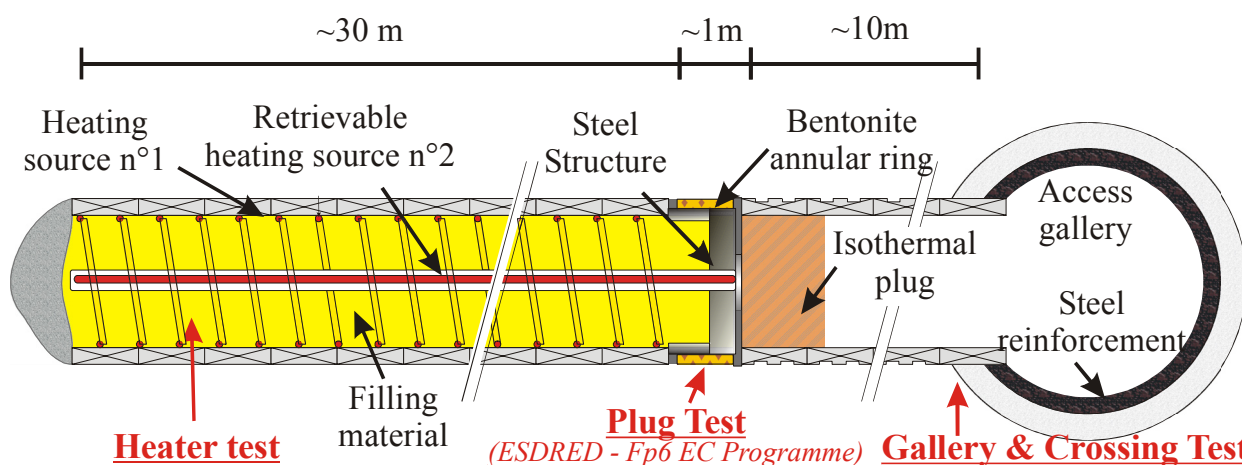

The PRACLAY experiments

The excavation will be performed under the protection of a shield and using the wedge block system for the lining. The method has to allow an excavation rate (excavation + installation of the lining) greater than 2m/day. At the end of the gallery a test will be done to assess the difficulty to restart with the tunnelling machine after a stopping period. The construction of the PRACLAY gallery requires a steel reinforcement ring in the connecting gallery. The maximum possible diameter for the opening in the connecting gallery is 2.55 m. Consequently, the nominal diameter of the extrados of the PRACLAY gallery has been fixed to 2.5 m taking into account the convergence. A diameter about 2.5 m corresponds to the range of diameters considered for the repository designs. The results of the gallery and crossing test will give additional information for the optimisation of the tunnel excavation and will demonstrate the feasibility to construct a crossing between an access gallery and a disposal gallery.

A large scale heater test is considered as a generic issue for all repository design, since at a distance larger than a few metres from the waste, the influence of the specific design on the temperature profile is limited. The large scale heater test has to demonstrate that the damaged zone of the host rock remains acceptable in terms of long term performance of the repository. It will be important to verify that fracturing remains acceptable and that the decrease of effective stress due to the increase of pore water pressure will not lead to the liquefaction of Boom Clay. The impact of the chemical processes on the transport properties of the Boom Clay will also be investigated. It has been chosen for the PRACLAY In Situ Experiment, to use a heater system imposing a as constant as possible temperature of about 80°C at the extrados gallery wall. However a second heater working at constant flux will also be installed as a back up of the first heater in case of failure. This back-up heater can be retrieve during the PRACLAY Heater Test.

Plugs (within disposal galleries, between disposal and main galleries, between main galleries and shafts) are considered, at least as a conservative measure, in the overall repository design in order to e.g., limit interactions between various repository zones (compartmentalisation through cutting the hydraulic connection along the gallery lining and EDZ), increase the resilience of the repository to intrusion, and avoid gas migration. The "PRACLAY Plug Test" aims at demonstrating that it is possible to cut-off hydraulically the EDZ and the engineered barriers of the disposal galleries with a horizontal plug.

The figure below gives an overview of the instrumentation programme including temperature, pore water, total stresses and displacements measurements as well as the follow-up of the chemical evolution in the Boom Clay around the test.

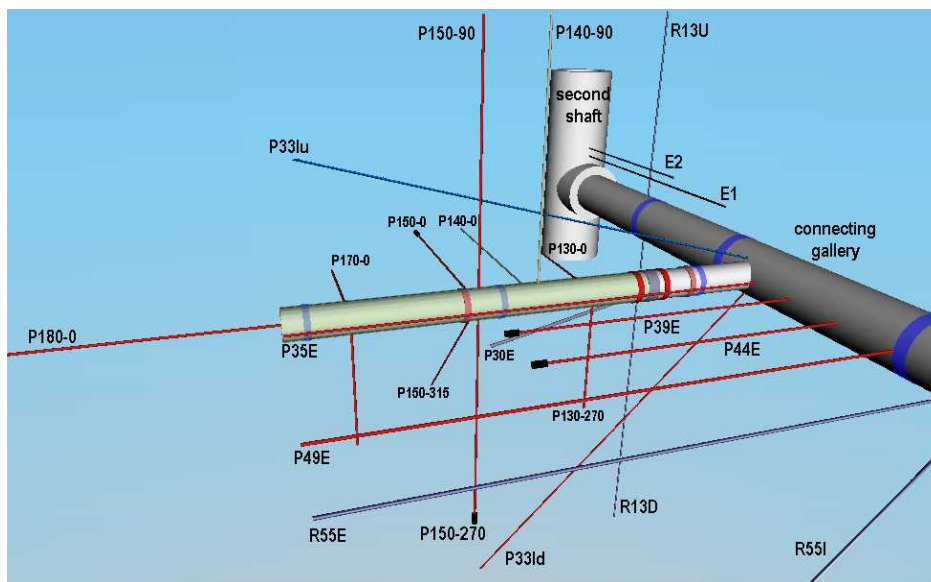

Lay-out of the instrumented boreholes around the PRACLAY gallery

Future work

The PRACLAY gallery will be constructed in the first semester of 2007 so that the experiments can be installed in 2008. The start of the heating phase is planned in the first semester of 2009. The EC project TIMODAZ (Thermal Impact on the Damaged Zone Around a Radioactive Waste Disposal in Clay Host Rocks) has been introduced in the frame of the 6th Framework Programme. In total 8 countries are represented (BE, FR, CH, DE, NL, ES, CZ, UK). If approved, the TIMODAZ project will give an important added value to the PRACLAY experiments.

Main contact person

Frédéric Bernier, frederic.bernier@sckcen.be